

Hwa Yao Technologies Co., Ltd



LLC400A Coaxial cable 100M/ROLL LLC400A



Drawing

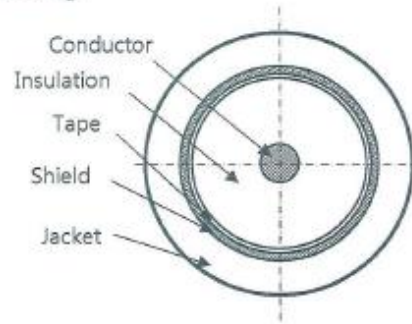

SPECIFICATIONS:

Construction

Item	Unit	Coaxial Cable
Conductor	Composition	No. 1
	Diameter	mm 2.74±0.03
	Material	/ Copper Clad Aluminum
Insulation	Diameter	mm 7.24±0.10
	Material	/ GAS-FPE
	Color	/ Nature
Shield	Tape Material	/ Double Aluminum Foil
	Composition	/ 24x6
	Braid Diameter	mm 0.12±0.008
	Braid Material	/ Tinned Copper
Coverage	%	67
Jacket	Diameter	mm 10.3±0.2
	Material	/ RoHS PVC
	Color	/ Black

Electrical Characteristic

Item	Unit	Standard			
Conductor resistance	Ω/km	4.6 ↓			
Insulation resistance	MΩ/km	1000 ↑			
Withstanding Voltage	V/ Min	1000			
Normal Impedance	Ω	50±3			
Normal Capacitance	pF/m	80±3			
Attenuation	MHZ	50	100	400	700
	dB/100ft	1.08	1.41	2.92	3.94
	MHZ	1575	3000	5800	6000
	dB/100ft	6.1	8.56	12.26	12.53

Printing : LLC400 LOW LOSS 50 OHM COAXIAL CABLE HYT8D

HwaYaotek

NO.6 ,Ln.48, Nansing Rd., Yong Kang City,
Tainan County 710, Taiwan, R.O.C

TEL: +886-6-2712809
FAX: +886-6-2712870
<http://www.hwayaotek.com.tw>
Email:sales@hwayaotek.com.tw

Coaxial Impedance (ML Method) Graphic result

Coaxial Impedance (ML Method) P1 -(PASS)

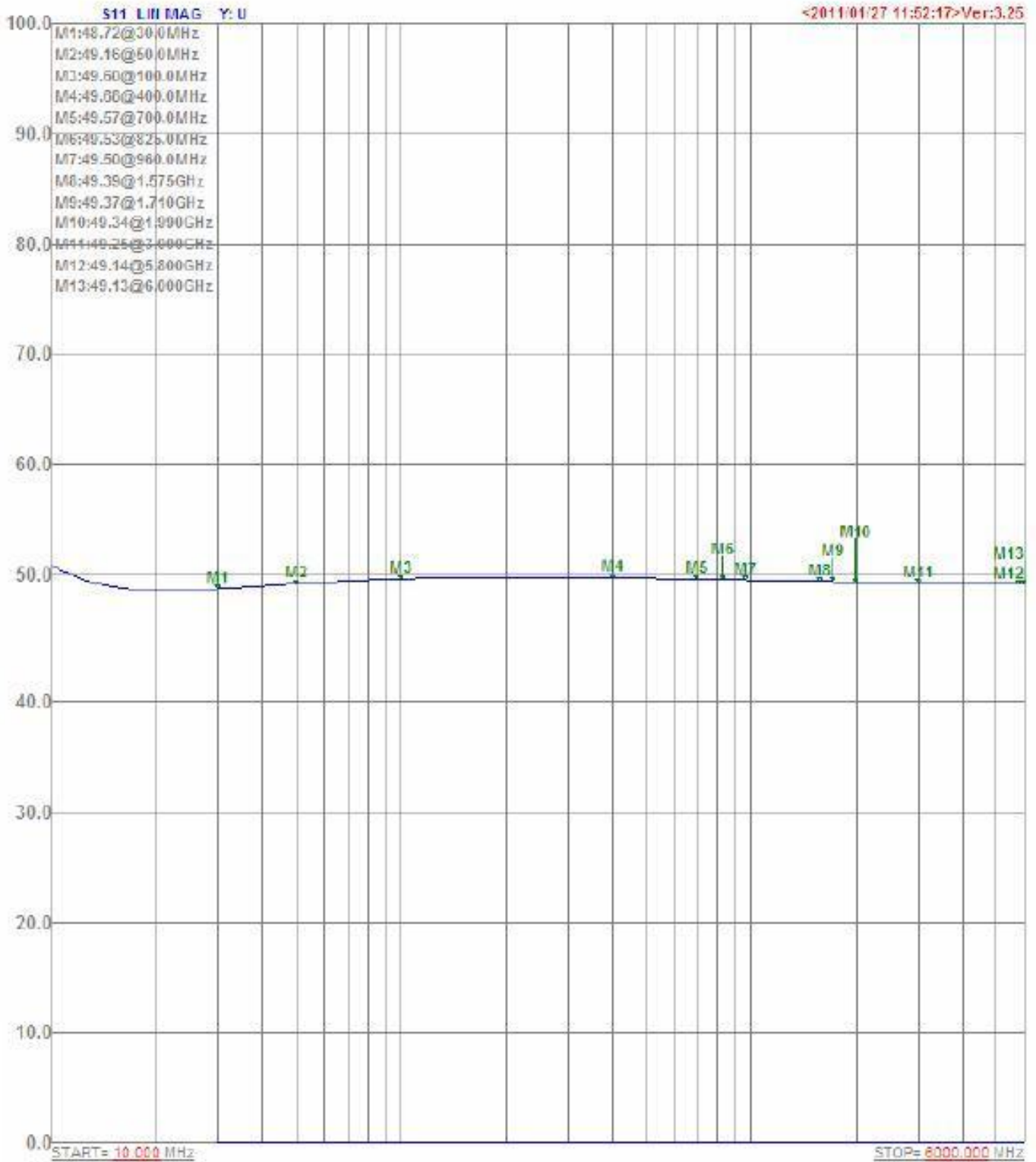

Coaxial Return Loss Graphic result

Coaxial Return Loss P1 -(PASS)

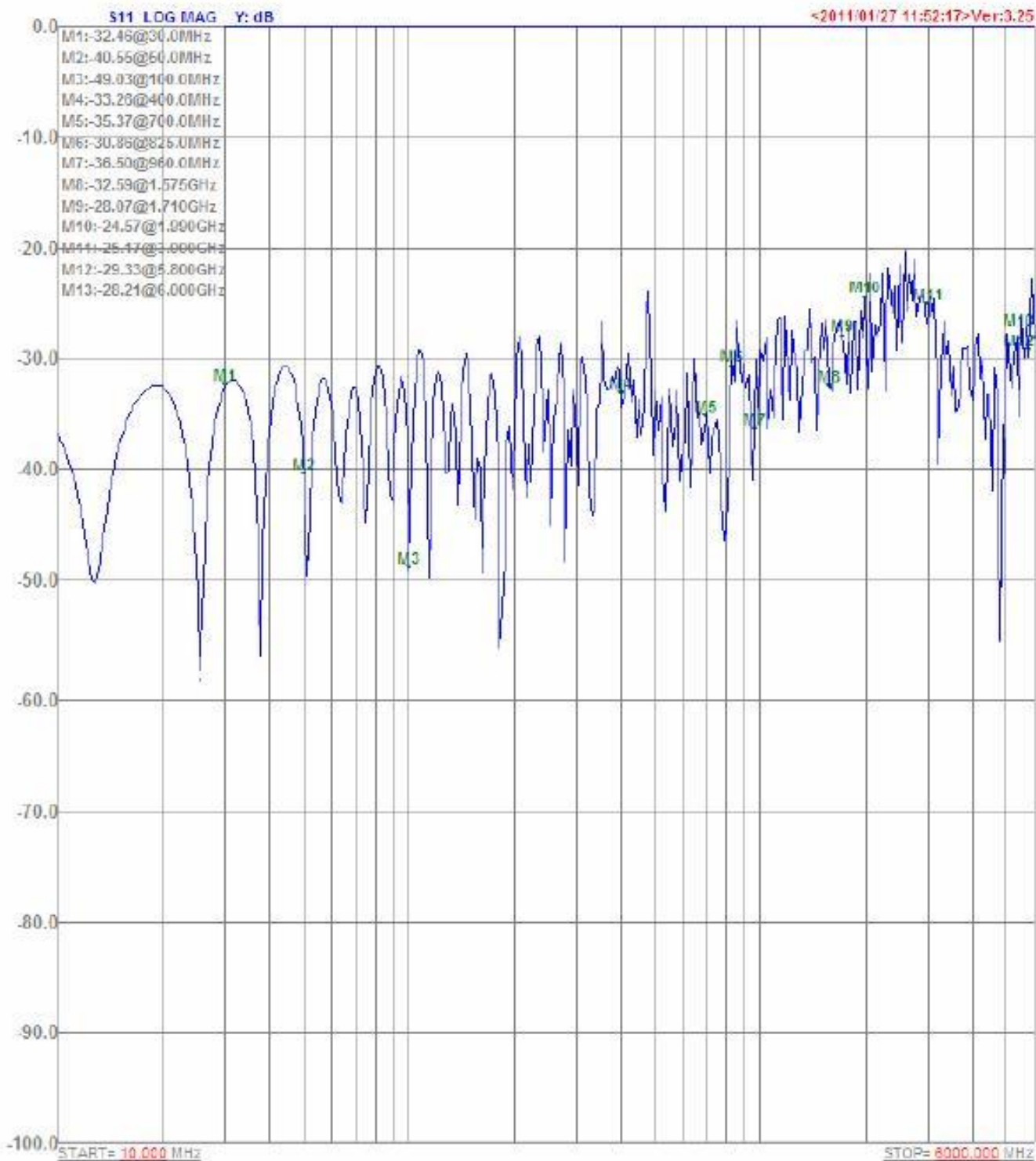

Coaxial SWR Graphic result

Coaxial SWR P1 (PASS)

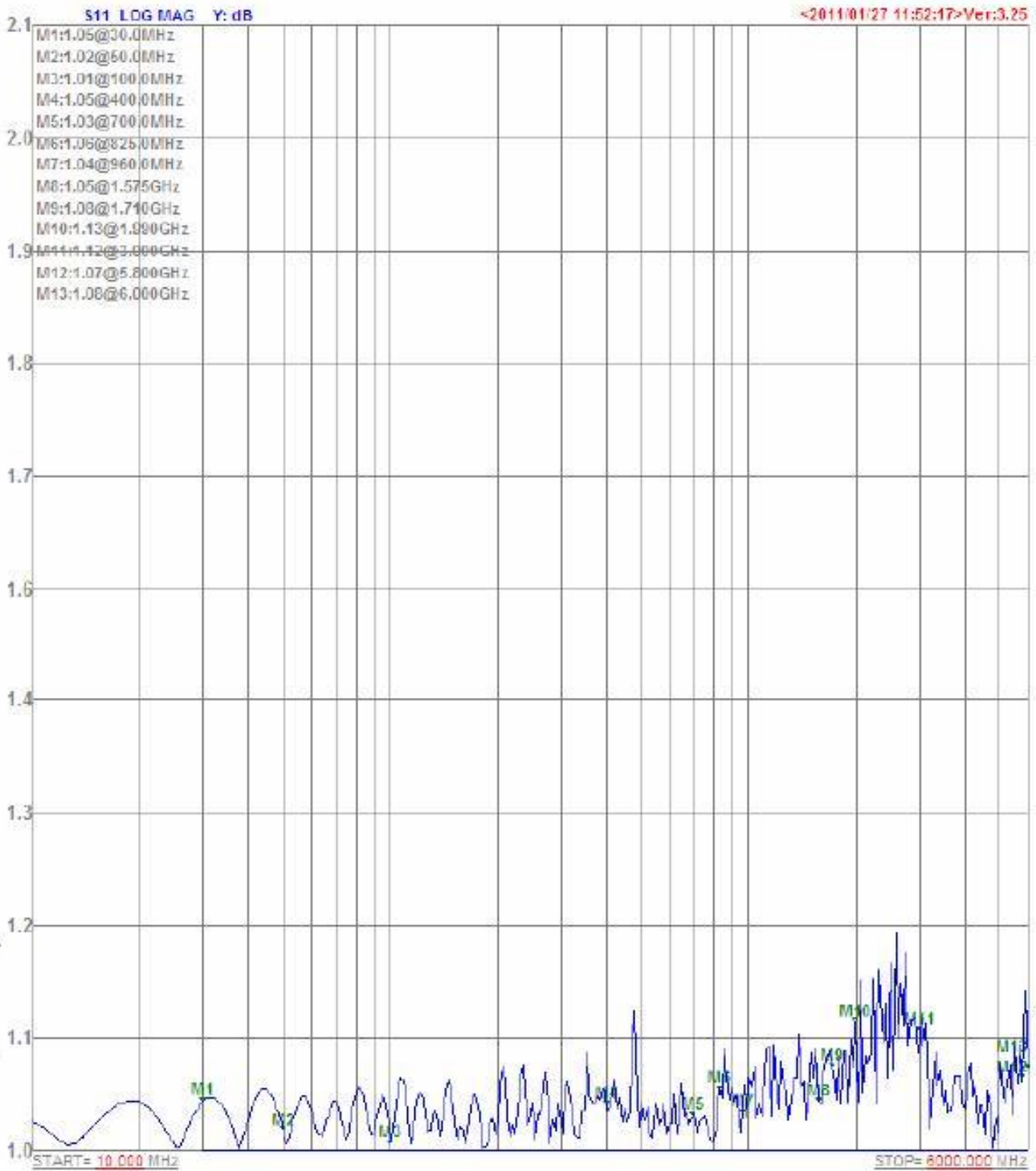

Hwayaotek

NO.6 ,Ln.48, Nansing Rd., Yong Kang City,
Tainan County 710, Taiwan, R.O.C

TEL: +886-6-2712809
FAX: +886-6-2712870
<http://www.hwayaotek.com.tw>
Email:sales@hwayaotek.com.tw

Coaxial Insertion Loss Graphic result

Coaxial Insertion Loss P1 (PASS)

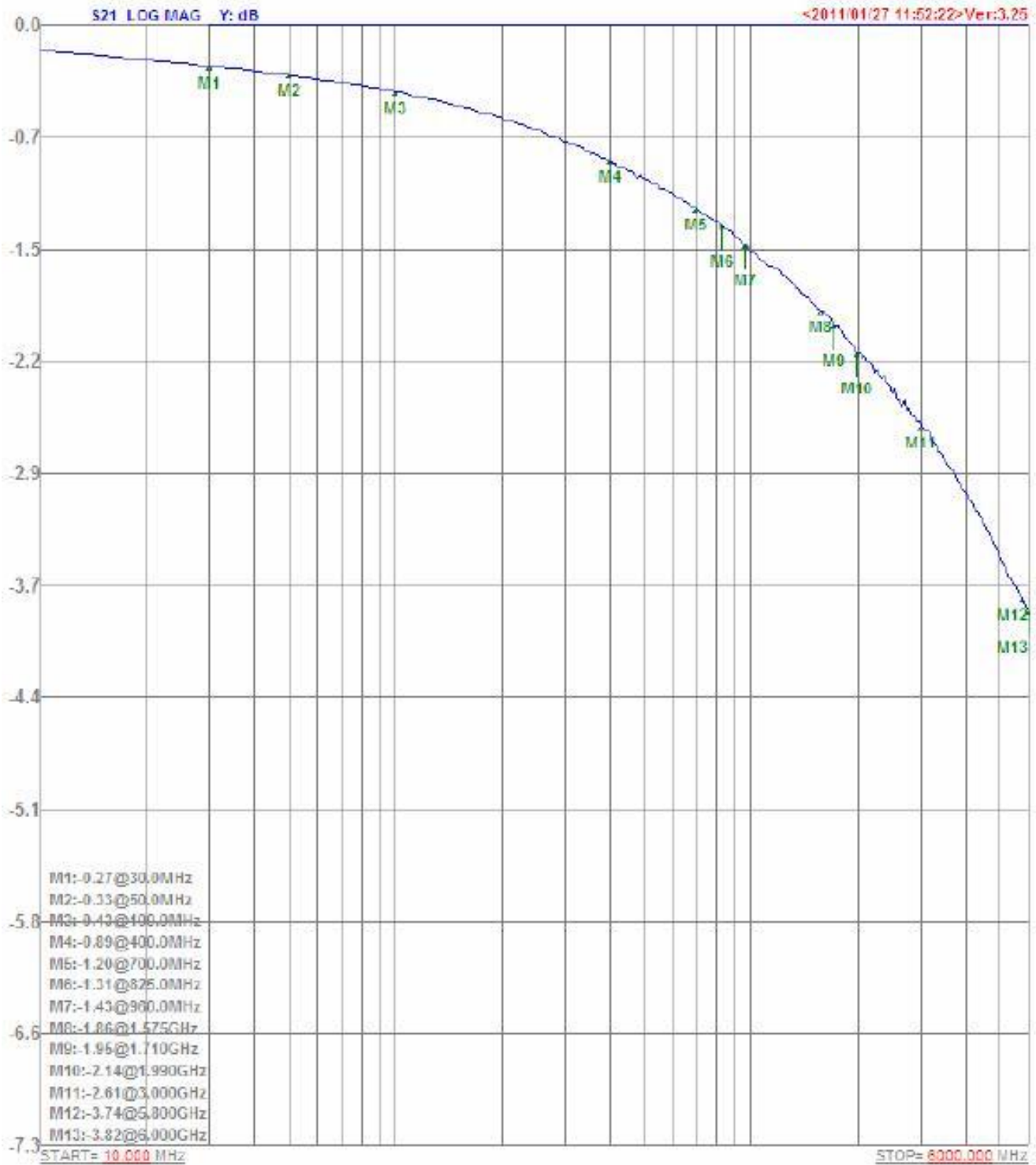

LMR[®]-400 Flexible Low Loss Communications Coax

Ideal for...

- Drop-in replacement for RG-8/9913 Air-Dielectric type Cable
- Jumper Assemblies in Wireless Communications Systems
- Short Antenna Feeder runs
- Any application (e.g. WLL, GPS, LMR, WLAN, WISP, WiMax, SCADA, Mobile Antennas) requiring an easily routed, low loss RF cable



• **LMR[®]** standard is a UV Resistant Polyethylene jacketed cable designed for 20-year service outdoor use. The bending and handling characteristics are significantly better than air-dielectric and corrugated hard-line cables.

• **LMR[®]-DB** is identical to standard LMR plus has the advantage of being watertight. The addition of waterproofing compound in and around the foil/braid insures continuous reliable service should the jacket be inadvertently damaged during installation or in the future.

• **LMR[®]-FR** is a non-halogen (non-toxic), low smoke, fire retardant cable designed for in-building runs that can be routed anywhere except air handling plenums. LMR-FR has a UL/NEC & CSA rating of 'CMR' and 'FT4' respectively. In addition, the LMR-FR series is MSHA-P rated for mining operations.

• **LMR[®]-FR-PVC** is a general-purpose indoor cable and has a UL/NEC & CSA rating of 'CMR' and 'FT4' respectively. It is less expensive than LMR-FR, however it emits toxic fumes (HCL) and greater smoke density when burned.

• **LMR[®]-PVC** is designed for low loss general-purpose indoor/outdoor applications and is somewhat more flexible than the standard polyethylene jacketed LMR.

• **LMR[®]-PVC-W** is a white-jacketed version of LMR-PVC for marine and other indoor/outdoor applications where color compatibility is desired.

• **Flexibility** and bendability are hallmarks of the LMR-400 cable design. The flexible outer conductor enables the tightest bend radius available for any cable of similar size and performance.

• **Low Loss** is another hallmark feature of LMR-400.

Size for size LMR has the lowest loss of any flexible cable and comparable loss to semirigid hard-line cables.

• **RF Shielding** is 50 dB greater than typical single shielded coax (40 dB). The multi-ply bonded foil outer conductor is rated conservatively at > 90 dB (i.e. >180 dB between two adjacent cables).

• **Weatherability:** LMR-400 cables designed for outdoor exposure incorporate the best materials for UV resistance and have life expectancy in excess of 20 years.

• **Connectors:** A wide variety of connectors are available for LMR-400 cable, including all common interface types, reverse polarity, and a choice of solder or non-solder center pins. Most LMR connectors employ crimp outer attachment using standard hex crimp sizes.

• **Cable Assemblies:** All LMR-400 cable types are available as pre-terminated cable assemblies. Refer to the section on FlexTech for further details.

Part Description					Stock
Part Number	Application	Jacket	Color	Code	
LMR-400	Outdoor	PE	Black	54001	
LMR-400-DB	Outdoor/Watertight	PE	Black	54091	
LMR-400-FR	Indoor -Riser CMR	FRPE	Black	54030	
LMR-400-FR-PVC	Indoor -Riser CMR	FRPVC	Black	54073	
LMR-400-PVC	Indoor/Outdoor	PVC	Black	54218	
LMR-400-PVC-W	Indoor/Outdoor	PVC	White	54204	

Construction Specifications			
Description	Material	In.	(mm)
Inner Conductor	Solid BCCAI	0.108	(2.74)
Dielectric	Foam PE	0.285	(7.24)
Outer Conductor	Aluminum Tape	0.291	(7.39)
Overall Braid	Tinned Copper	0.320	(8.13)
Jacket	(see table above)	0.405	(10.29)

Mechanical Specifications			
Performance Property	Units	US	(metric)
Bend Radius: installation	in. (mm)	1.00	(25.4)
Bend Radius: repeated	in. (mm)	4.0	(101.6)
Bending Moment	ft-lb (N-m)	0.5	(0.68)
Weight	lb/ft (kg/m)	0.068	(0.10)
Tensile Strength	lb (kg)	160	(72.6)
Flat Plate Crush	lb/in. (kg/mm)	40	(0.71)

Electrical Specifications			
Performance Property	Units	US	(metric)
Cutoff Frequency	GHz		16.2
Velocity of Propagation	%		85
Dielectric Constant	NA		1.38
Time Delay	nS/ft (nS/m)	1.20	(3.92)
Impedance	ohms		50
Capacitance	pF/ft (pF/m)	23.9	(78.4)
Inductance	uH/ft (uH/m)	0.060	(0.20)
Shielding Effectiveness	dB		>90
DC Resistance			
Inner Conductor	ohms/1000ft (/km)	1.39	(4.6)
Outer Conductor	ohms/1000ft (/km)	1.65	(5.4)
Voltage Withstand	Volts DC		2500
Jacket Spark	Volts RMS		8000
Peak Power	kW		16

Environmental Specifications		
Performance Property	°F	°C
Installation Temperature Range	-40/+185	-40/+85
Storage Temperature Range	-94/+185	-70/+85
Operating Temperature Range	-40/+185	-40/+85

Attenuation vs. Frequency (typical)

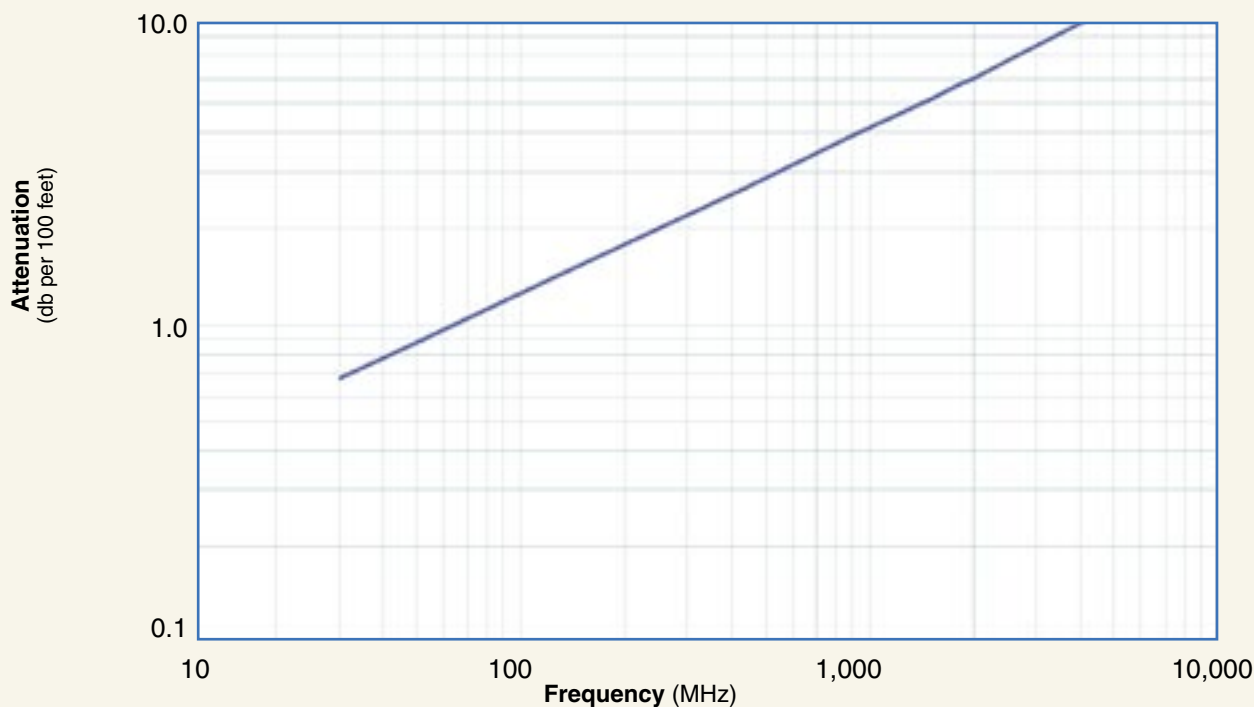

Frequency (MHz)	30	50	150	220	450	900	1500	1800	2000	2500	5800
Attenuation dB/100 ft	0.7	0.9	1.5	1.9	2.7	3.9	5.1	5.7	6.0	6.8	10.8
Attenuation dB/100 m	2.2	2.9	5.0	6.1	8.9	12.8	16.8	18.6	19.6	22.2	35.5
Avg. Power kW	3.33	2.57	1.47	1.20	0.83	0.58	0.44	0.40	0.37	0.33	0.21

Calculate Attenuation =
 $(0.122290) \cdot \sqrt{\text{FMHz}} + (0.000260) \cdot \text{FMHz}$ (interactive calculator available at http://www.timesmicrowave.com/cable_calculators)

Attenuation:

VSWR=1.0 ; Ambient = +25°C (77°F)

Power:

VSWR=1.0; Ambient = +40°C; Inner Conductor = 100°C (212°F); Sea Level; dry air; atmospheric pressure; no solar loading

LMR[®]-400

Flexible Low Loss Communications Coax



-Connectors

Interface	Description	Part Number	Stock Code	VSWR** Freq. (GHz)	Coupling Nut	Inner Contact Attach	Outer Contact Attach	Finish* Body /Pin	Length in (mm)	Width in (mm)	Weight lb (g)
7-16 DIN Female	Straight Jack	TC-400-716-FC	3190-376	<1.25:1(2.5)	NA	Solder	Clamp	S/S	1.6 (41)	1.13 (28.7)	0.281 (127.5)
7-16 DIN Male	Straight Plug	TC-400-716-MC	3190-279	<1.25:1(2.5)	Hex	Solder	Clamp	S/S	1.4 (36)	1.40 (35.6)	0.268 (121.6)
7-16 DIN Male	Right Angle	TC-400-716MC-RA	3190-1671	<1.25:1(<3)	Hex	Solder	Clamp	A/S	2.4 (61.5)	1.88 (47.8)	0.35 (159)
BNC Male	Straight Plug	TC-400-BM	3190-318	<1.25:1(2.5)	Knurl	Solder	Crimp	N/S	1.7 (43)	0.56 (14.2)	0.063 (28.6)
HN Male	Straight Plug	TC-400-HNM	3190-923	<1.25:(<1)	Knurl	Solder	Clamp	S/G	2.3 (59.2)	0.88 (22.4)	0.25 (113.4)
QDS Male	Straight Plug	TC-400-QDSM	3190-620	<1.25:(<3)	Knurl	Solder	Clamp	A/G	1.8 (46.6)	1.00 (25.4)	0.25 (113.4)
Mini-UHF	Straight Plug	TC-400-MUHF	3190-520	<1.25:1(2.5)	Knurl	Solder	Crimp	N/G	1.1 (28)	0.50 (12.7)	0.020 (9.1)
N Female	Straight Jack	TC-400-NFC	3190-299	<1.25:1 (2.5)	NA	Solder	Clamp	N/S	1.6 (41)	0.75 (19.1)	0.119 (54.0)
	Straight Plug	EZ-400-NFC-2	3190-1907	<1.25:1(2.5)	NA	Spring Finger	Clamp	N/G	1.5 (38)	0.89 (22.6)	0.121 (54.9)
	Straight Jack	EZ-400-NF	3190-956	<1.25:1(2.5)	NA	Spring Finger	Crimp	N/G	1.8 (45)	0.66 (16.8)	0.105 (47.6)
	Bulkhead Jack	EZ-400-NF-BH	3190-518*	<1.25:1(2.5)	NA	Spring Finger	Crimp	N/G	1.8 (46)	0.88 (22.4)	0.102 (46.3)
	Bulkhead Jack	TC-400-NFC-BH (A)	3190-872	<1.25:1(2.5)	NA	Solder	Clamp	A/G	1.8 (46)	0.88 (22.4)	0.145 (65.8)
N Male	Straight Plug	SC-400-NM	3190-1454	<1.25:1(2.5)	Knurl	Solder	Crimp	N/G	1.5 (38)	0.75 (19.1)	0.090 (40.8)
	Straight Plug	TC-400-NM	3190-188	<1.25:1(2.5)	Knurl	Solder	Crimp	N/G	1.5 (38)	0.75 (19.1)	0.090 (40.8)
	Straight Plug	TC-400-NMC	3190-277	<1.25:1(2.5)	Knurl	Solder	Clamp	N/G	1.5 (38)	0.70 (17.8)	0.121 (54.9)
	Straight Plug	EZ-400-NMC-2	3190-1906	<1.25:1(2.5)	Hex/Knurl	Spring Finger	Clamp	N/G	1.5 (38)	0.75 (19.1)	0.121 (54.9)
	Straight Plug	EZ-400-NMH-D	3190-400*	<1.25:1(10)	Hex/Knurl	Spring Finger	Crimp	A/G	1.5 (38)	0.89 (22.6)	0.103 (46.8)
	Straight Plug	TC-400-NMH-D	3190-552	<1.25:1(10)	Hex/Knurl	Solder	Crimp	A/G	1.5 (38)	0.89 (22.6)	0.113 (51.3)
	Straight Plug	EZ-400-NMK	3190-661	<1.25:1(10)	Knurl	Spring Finger	Crimp	S/G	1.5 (38)	0.75 (22.6)	0.113 (51.3)
	Right Angle	TC-400-NMH-RA-D	3190-2293*	<1.35:1(6)	Hex/Knurl	Solder	Crimp	A/G	1.8 (46)	1.25 (31.8)	0.130 (59.0)
	Right Angle	TC-400-NMC-RA (A)	3190-870	<1.35:1(2.5)	Hex	Solder	Clamp	A/G	1.8 (46)	1.25 (31.8)	0.150 (68.0)
	Right Angle	EZ-400-NMH-RA	3190-761	<1.35:1(2.5)	Hex	Spring Finger	Crimp	S/G	1.8 (46)	1.25 (31.8)	0.130 (59.0)
	Reverse Polarity	TC-400-NM-RP	3190-960	<1.25:1(2.5)	Knurl	Solder	Crimp	N/G	1.5 (38)	0.75 (19.1)	0.090 (40.8)
SMA Male	Straight Plug	TC-400-SM	3190-439	<1.25:1(8)	Hex	Solder	Crimp	N/G	1.2 (29)	0.50 (12.7)	0.032 (14.5)
TNC Female	Reverse Polarity	TC-400-TF-RP	3190-1063	<1.25:1(2.5)	NA	Solder	Crimp	N/G	1.8 (46)	0.55 (14.0)	0.074 (33.6)
	Reverse Polarity	EZ-400-TF-RP	3190-795	<1.25:1(2.5)	-NA	Spring Finger	Crimp	A/G	1.8 (46)	0.55 (14.0)	0.074 (33.6)
TNC Male	Straight Plug	TC-400-TM	3190-260	<1.25:1(2.5)	Knurl	Solder	Crimp	N/S	1.7 (43)	0.59 (15.0)	0.074 (33.6)
	Straight Plug	EZ-400-TM	3190-650	<1.25:1(2.5)	Knurl	Spring Finger	Crimp	N/S	1.7 (43)	0.59 (15.0)	0.074 (33.6)
	Right Angle	TC-400-TM-RA	3190-442*	<1.35:1(2.5)	Knurl	Solder	Crimp	N/G	1.7 (43)	0.59 (15.0)	0.085 (38.6)
	Reverse Polarity	TC-400-TM-RP	3190-1062	<1.25:1(2.5)	Knurl	Solder	Crimp	N/G	1.7 (43)	0.59 (15.0)	0.074 (33.6)
	Reverse Polarity	EZ-400-TM-RP	3190-794	<1.25:1(2.5)	Knurl	Spring Finger	Crimp	A/G	1.7 (43)	0.59 (15.0)	0.074 (33.6)
UHF Male	Straight Plug	EZ-400-UM	3190-997	<1.25:1(2.5)	Knurl	Spring Finger	Crimp	N/G	1.9 (48)	0.80 (20.3)	0.090 (40.8)

* Finish metals: N=Nickel, S=Silver, G=Gold, SS=Stainless Steel, A=Alballoy **VSWR spec based on 3 foot cable with a connector pair *Available in bulk pack



Hardware Accessories

Type	Part Number	Stock Code	Description
Ground Kit	GK-S400TT	GK-S400TT	Standard Grounding Kit (each)
Hoisting Grip	HG-400T	HG-400T	Laced Type (each)



Install Tools

Type	Part Number	Stock Code	Description
Crimp Tool	HX-4	3190-200	Crimp Handle
Crimp Dies	Y1719	3190-202	.429" Hex Dies
Crimp Tool	CT-400/300	3190-666	Crimp tool for LMR 400 connectors
Crimp Rings	CR-400	3190-830	Crimp rings for TC/EZ-400 connectors (package of 10)
Strip Tool	ST-400C-2	3190-1972	Prep tool for EZ-400-NMC-2 two piece clamp style connector
Strip Tool	CST-400	3192-004	Combination prep tool for LMR-400 crimp and clamp style connectors
Mid-Span Strip Tool	GST-400	3190-2174	For ground strap attachment
Replacement Blades	RB-456	3190-421	Replacement blades for Strip Tool
Deburr Tool	DBT-U	3192-001	Removes center conductor rough edges
Cutting Tool	CCT-01	3190-1544	Cable end flush cut tool
Replacement Blade	RB-01	3190-1609	Replacement blade for cutting tool
Tool Kit	TK-400EZ	3190-1601	Tool kit for LMR-400 Crimp Connectors (includes CCT-01, CST-400, CT-400/300, DBT-U, Tool Pouch)